

Technical Data Sheet

pneum. Multi-Spring-Actuator

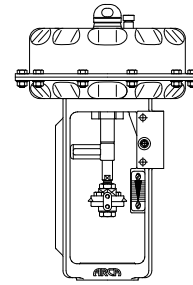

TD_812

General Data

Series	812
Diaphragm effective area	MFI: 320 cm ² / MFIII: 720 cm ²
Stroke	20 - 60 mm
Control signal	6 bar max.
Materials	Actuator housing: 1.0332 powder coated (option: stainless steel 1.4301) Diaphragm plate: MFI-1.0332 galvanized, MFIII-1.0037 galvanized Yoke: 1.6220 (option: stainless steel 1.4308) Stem: 1.4122 (option: Duplex 1.4462) Springs: 1.1230 plastic-covered Diaphragm: NBR fabric-reinforced (moulded) Sealing element: high-quality, special polyurethane
Spring chamber	Optionally with instrument air purge
Operating temperature	-20°C to +80°C (Option -40°C to + 80°C)
No. of springs	MFI: 3-7 / MFIII: 3-12
Air connections	Connection Z1: G ¹ / ₈ ; Connection Z2: MFI: G ¹ / ₈ / MFIII: G ¹ / ₄
Control force spring max.	4,8 – 22 kN
Control force air max.	14,4 – 35,2 kN

Functional description

The ARCAPAQ® is a pneumatic multi-spring diaphragm actuator with spring return (fail safe) and is used to actuate linear valves. The actuator positions the valve plug in dependence of the signal pressure acting upon the actuator diaphragm, which in turn is controlled by a pneumatic or electro-pneumatic positioner. These actuators can be operated in the "air to open" function or with the reverse action "air to close".

- The actuator has a compact design with a low installed height. Various spring sets with different bench ranges ensure good adaptation to the particular operating conditions.
- A fabric-reinforced rolling-diaphragm ensures smooth conversion of the pneumatic signal pressure into the linear motion of the actuator stem. The diaphragm (4), supported by the diaphragm plate (5), is connected to the actuator stem (8) and separates the actuator housing (2) into pressure and spring chamber. If the force of the pneumatic signal pressure exceeds the opposing spring force (3), the actuator stem (8) moves and actuates the reciprocating valve.
- The signal pressure is routed to the diaphragm chamber via internal channels in the yoke (10). The air vent of the spring chamber is done by means of the protective cap (1), which is impermeable to splash water. Optionally the spring chamber can be purged with instrument air from the positioner either through internal channels or by outside tubing.
- The yoke (10) connects the actuator to the control valve. The actuator stem (8) is connected to the valve stem via the coupling (9), which also acts as a stroke indicator, and is securely guided in the slide bearing (6) and sealed with a special sealing element (7) with wiper ring.

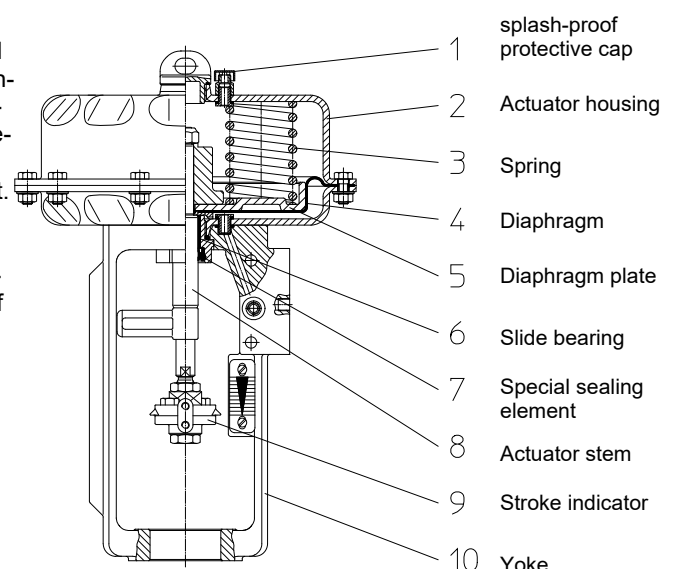

Technical Data Sheet

pneum. Multi-Spring-Actuator

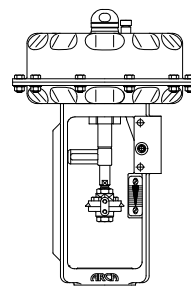

TD_812

Control forces and control ranges

Opening function (air to open - spring to close)

Size	Diaphragm surface (cm ²)	Type	No. of springs	Stroke (mm)	Control range		Control force (kN)	Force diagram (page 4)
					from (bar)	to (bar)		
MFI-20	320	812-213..	3	20	0,75	1,5	2,4	IA
			6		1,5	3,0	4,8	
MFI-20(v)		812-224..	3		1,0	1,5	3,2	IB
			6		2,0	3,0	6,4	
			7		2,3	3,5	7,4	
MFI-30		720	812-234..		3	30	0,75	1,5
	6			1,5	3,0		4,8	
MFIII-30	812-334..		3	0,7	1,5		5	IIIA
			6	1,5	3,0		10	
			9	1,8	3,7		13	
			12	2,2	4,4		16	
MFIII-30(v)	812-336..	3	1,1	1,5	7,5	IIIB		
		6	2,2	3,0	15			
		9	2,7	3,6	19			
MFIII-60	812-346..	3	0,7	1,5	5	IV		
		6	1,4	3,0	10			
		9	1,7	3,6	12			
		12	2,0	4,3	14			

Closing function (air to close - spring to open)

Size	Diaphragm surface (cm ²)	Type	No. of springs	Stroke (mm)	Control pressure min. bar	Control force (kN) depending on control pressure				
						2,0 bar	3,0 bar	4,0 bar	5,0 bar	6,0 bar
MFI-20	320	812-213..	3	20	1,5	1,6	4,8	8,0	11,2	14,4
			6		3,0	-	-	3,2	6,4	9,6
MFI-20(v)		812-224..	3		1,5	-	4,8	8,0	11,2	14,4
			6		3,0	-	-	3,2	6,4	9,6
			7		3,5	-	-	1,6	4,8	8,0
MFI-30		720	812-234..		3	30	1,5	1,6	4,8	8,0
	6			3,0	-		-	3,2	6,4	9,6
MFIII-30	812-334..		3	1,5	3,6		10,8	18	25,2	32,4
			6	3,0	-		-	7,2	14,4	21,6
			9	3,7	-		-	2,2	9,4	16,6
			12	4,4	-		-	-	4,3	11,5
MFIII-30(v)	812-336..	3	1,1	6,4	13,6	20,8	28	35,2		
		6	2,2	-	5,7	12,9	20,1	27,3		
		9	2,6	-	2,8	10	17,2	24,4		
MFIII-60	812-346..	3	3,1	-	-	6,4	13,6	20,8		
		6	1,5	3,6	10,8	18	25,2	32,4		
		9	3,0	-	-	7,2	14,4	21,6		
		12	3,6	-	-	2,9	10,1	17,3		
					4,3	-	-	-	5,0	12,2

Caution: The actuator forces and spring ranges listed above are for actuator without valve at nominal stroke only

Technical Data Sheet

pneum. Multi-Spring-Actuator

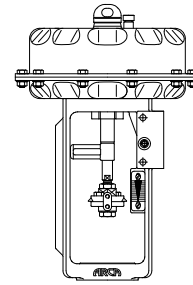

TD_812

Dimensions and weights

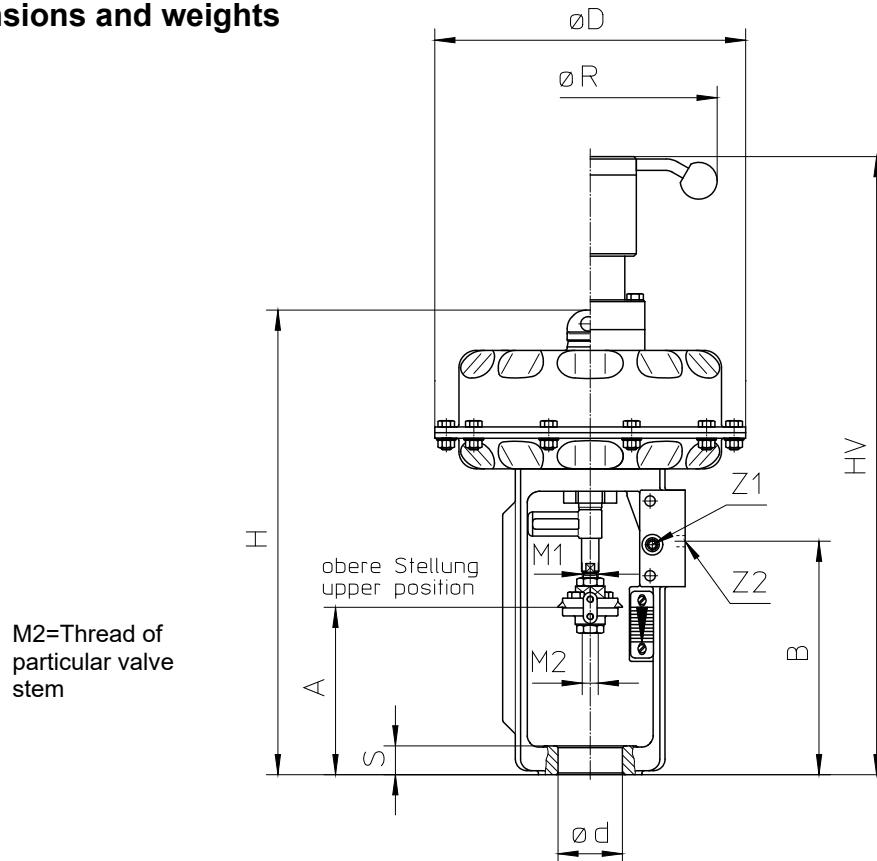

Size	Diaphragm surface (cm ²)	Type	Weight	No. of springs	Stroke (mm)	Ø D (mm)	M1 actuator	Ø d (mm)	S (mm)	A (mm)	B (mm)	H (mm)	HV (mm)	Ø R (mm)			
MFI-20	320	812-213..	14	3	20	270	M14	40	20	120	180	361	508	220			
				6													
812-223..		3	20	48	20			120				180	381		528		
		6															
MFI-20(v)		812-224..	3	15	20			48				20	120		180	381	528
			6														
MFI-30	812-234..	3	16	3	20	48	20	120	180	381	528						
		6															
MFIII-30	720	812-334..	40	3	30	400	M20x1,5	56	25	142	203	404	551	335			
				6													
812-336..		42	3	30	56			25			142	203	404		551	814	
			6														
MFIII-30(v)		812-336..	3	42	30			56			25	142	203		404	551	814
			6														
812-346..	44	3	16	30	56	25	142	203	404	551	814						
		6															
MFIII-60	812-346..	3	45	60	72	30	192	309	625	888							
		6															
812-346..	47	3	16	30	72	30	192	309	625	888							
		6															



Technical Data Sheet

pneum. Multi-Spring-Actuator

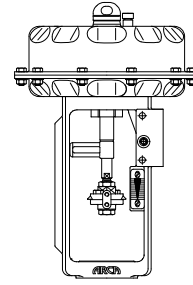

TD_812

Force diagrams

IA MFI-20

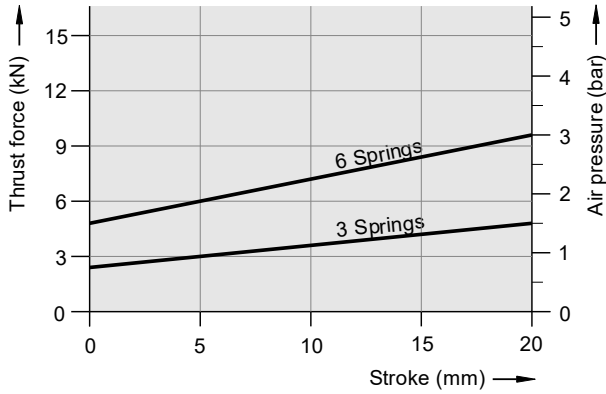

IB MFI-20(v)

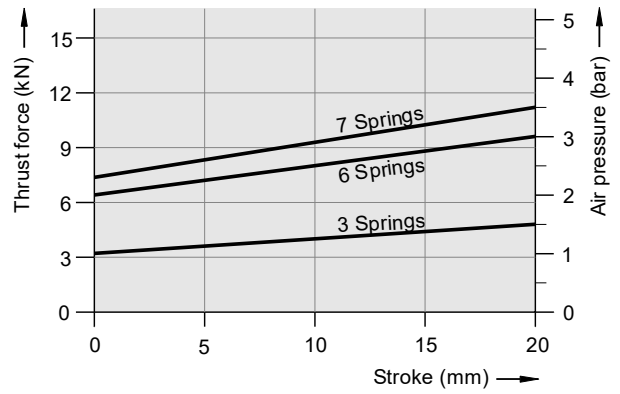

II MFI-30

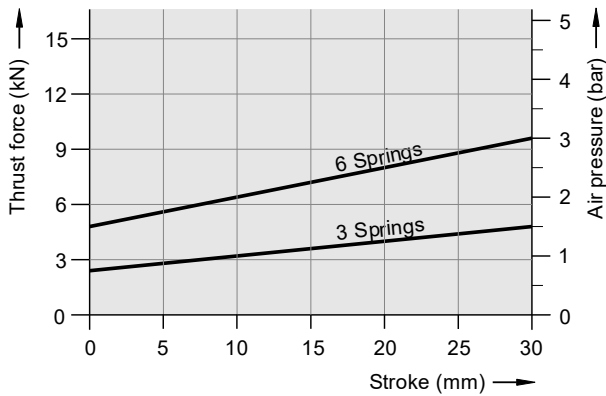

IIIA MFIII-30

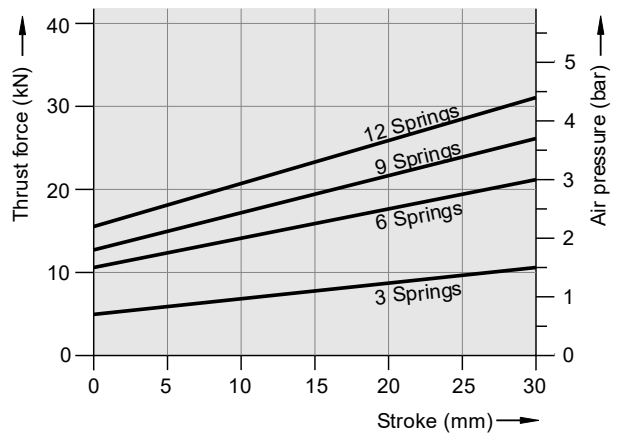

IIIB MFIII-30(v)

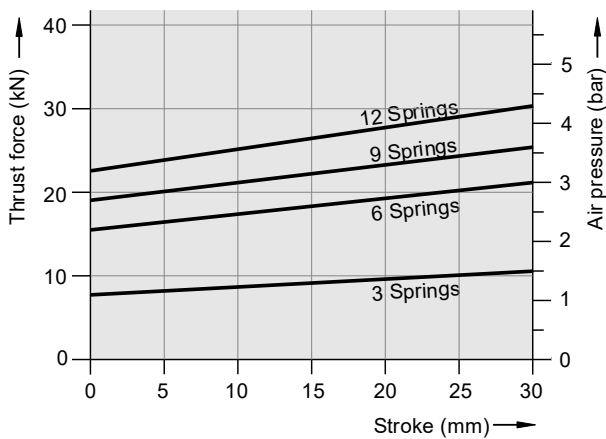

IV MFIII-60

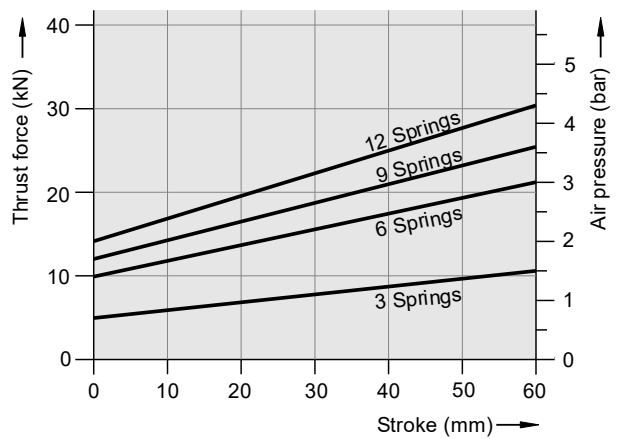

Caution: The actuator forces and spring ranges listed above are for actuator without valve at nominal stroke only

Technical Data Sheet

pneum. Multi-Spring-Actuator

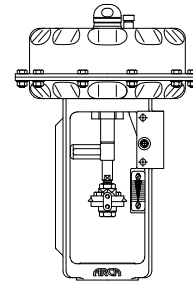

TD_812

Type code

812 -2 2 3 3 N- O B 0 -HV

Series

Actuator size

- 2 MFI diaphragm surface 320 cm²
- 3 MFIII diaphragm surface 720 cm²

Yoke (ø = adapter in mm)

0	1	2	3	4	9
w/o	ø40	ø48	ø56	ø72	special

Hub

3	4	6
20 mm	30 mm	60 mm

Spring set

3	6	7	9	0
3 springs	6 springs	7 springs	9 springs	12 springs

Material of diaphragm chamber

- N = diaphragm head steel / yoke steel
- A = diaphragm head steel / yoke stainless steel
- V = diaphragm head stainless steel / yoke stainless steel

Function

- O = springs move the stem downwards (air to open)
- S = springs move the stem upwards (air to close)

Execution

- B = actuator reversible, w/o spring chamber purge
- E = actuator reversible, with integrated spring chamber purge

Extra equipment

- 0 = w/o
- 1 = stroke limitation in the opening direction
- 4 = low temperature -40° C
- 5 = air connection G 1/2"
- 6 = screws stainless steel (long)
- AP = outer parts in stainless steel passivated
- B = stroke limitation adjustable for both direction O/S
- EXG = Explosion-proof version Gas (Zone 1 & 2)
- EXD = Explosion-proof version Dust + Gas (Zone 21 & 22 + Zone 1 & 2)
- FG = spring cover 180° rotated
- S = on/off actuator
- SD = stem 1.4462 (Duplex) (incl. 6)
- V = actuator preloaded
- VB = for VDI/VDE-mounting (incl. 6 + FG)
- X = peripheral bolting XYLAN coated
- Z = peripheral bolting ASME design

Handwheel

- = w/o
- HV = with handwheel (can not be combined with 1 and B)